



Owner's Manual

LV12W2-EU / LV30W2-EU

CRUISYM **α**

1.	Contents	1
2.	Before Riding	3
3.	Safe Riding	3
4.	Driving	4
5.	Use Genuine Spare Parts	4
6.	Parts Location	5
	Combination instrument	7
	Ignition switch	12
	Right handlebar switches	14
	Left handlebar switches	14
	Windscreen	15
	Fuel tank cap	16
	Front compartment	17
	Luggage box	17
	Side stand	18
	Main stand	18
	Passenger footrest	19
7.	How to Start the Engine	19
	To start the engine	19
	To stop the engine	19
8.	How to Ride the Scooter	20
	Break-in	19
	Throttle control	20
	Moving off	20
	Breaking	20
	Anti-lock Brake System	21
	Traction Control System	21
	Park the scooter	22
9.	Maintenance and Adjustment	23
	Importance of maintenance	23
	Routine checks	23
	Oil level inspection / oil change	24
	Transmission oil change	25
	Fuel inspection	25
	Coolant level inspection / filling	26
	Coolant change	26
	Brake system inspection	27

Throttle free play inspection	28
Tire / tire pressure inspection	28
Steering / front fork inspection	28
Fuse inspection	29
Battery inspection	29
Spark plug inspection	30
Air cleaner/ V-belt air cleaner inspection	30
Headlight adjustment	31
Rear shock absorber adjustment	31
General lubrication	31
Vehicle data recorder	31
10. Taking Care of Your Scooter	32
Washing	32
11. Trouble Shooting	33
Diagnosis when engine does not start	33
Overheating	33
EFi warning indicator on	33
ABS indicator light on	33
12. Periodic Maintenance Schedule	34
13. Specification	35
14. Serial Number/Labels Location	37





2. Before Riding

This manual describes the correct usage of this scooter including safety riding, simple inspection methods and so on.

For a more comfortable and safety riding, please read this manual carefully.

For your benefit, please ask your authorized **SYM** dealer the operating manual and carefully read the following:

- Correct use of the scooter.
- Pre-delivery inspection and maintenance.

Thank you very much for your patronage

In order to maximize your scooter's performance, a periodical inspection and maintenance should be completely carried out.

We recommend that after riding your new scooter for the first 300 kilometers, you should take your scooter to the original dealer for an initial inspection, and to have your scooter inspected periodically every 1000 kilometers thereafter.

- In case the scooter's specifications and construction are modified and different from the photos and diagrams on the owner's manual / catalogues, the specifications and construction of the actual scooter shall prevail.

3. Safe Riding

It is very important to be relaxed and clothe properly when driving, and observe traffic regulations. Do not rush and always drive carefully.

Usually, most people would ride their newly bought scooter very carefully, but after they became familiar with their scooters, they tended to become reckless which may result in an accident.

To remind you:

- Please wear a safety helmet, and properly tighten the chin belt when riding a scooter.
- Clothes with open or loose cuffs may be blown by wind and cause the cuffs to get caught on the steering handle and thus affects riding safety.
- So, put on clothes with tight sleeves.
- Hold the steering handle by both hands when riding. Never ride with only one hand.
- Observe the speed limit.
- Wear suitable low-heel shoes.
- **Perform periodical maintenance and inspection in accordance with the schedule.**

WARNING!!

- To avoid getting burned by exhaust pipe when taking a passenger. Make sure your passenger has put his/her feet on the pedals.
- After running, the exhaust pipe is very hot, be careful not to get burned when conducting an inspection or maintenance.
- After running, the exhaust pipe is very hot; select a suitable location to park your scooter to avoid others getting burned by the exhaust pipe.

CAUTION:

- Modified scooter will affect its structure or performance, and cause poor engine operation or exhaust noise, which will result in shortening the scooter's service life.
Besides, modification is illegal and does not conform to the original design and specifications.
A modified scooter will not be covered by warranty; therefore, do not modify your scooter at will.
- Tire and rim modifications will make it unsafe to ride and may cause severe injury or death.



4. Driving

Keep the related parts of your body such as arms, palms, lumbar, and toes relax and ride with the most comfortable posture in order to be able to react quickly whenever it is necessary.

- Rider's posture will greatly affect riding safety. Always keep your body's gravity in the center of the saddle, if your body's gravity is on the rear part of saddle, the front wheel load will be reduced, and this will cause the steering handle shaking. It is dangerous to ride a scooter with an unstable handle.
- It will be much easier to make a turn if rider inclines his body inward when turning. On the other hand, the rider will feel unstable if his body and the scooter do not incline.
- The scooter is hard to control on a bumpy, unlevelled, unpaved road, try to know the road conditions in advance, slow down and use your shoulder's force to control the handle.
- Suggestion: Do not load objects on the front pedals unnecessarily, to avoid affecting the riding safety and the operation of steering handle.

CAUTION:

- The rider's feeling on the handle is slightly different with a load or without a load.
- Overload may cause the handle to swing and affect the riding safety.
- Therefore, do not overload your scooter.
- Overloading the scooter will cause the scooter to become unstable and hard to maneuver, it may cause serious damage to the tires and rims, as well as it may change the center of gravity, which could result in an accident that could cause injury or death. Do not exceed the maximum authorized load.

CAUTION:

- Do not place flammable materials such as rags between the body side cover and engine to avoid components damaging by fire.
- Do not load objects on areas not specified for loading to avoid damage.

SUGGESTION

To maximize the scooter's performance and prolong its service life:

The first month or first 1000km is the wear- in period for the engine and components.

Avoid rapid acceleration, and keep the speed below 60km/hr.

5. Use Genuine Spare Parts

In order to maintain the scooter's best performance, each part's quality, material, and machined precision must conform to the design requirements. "**SYM Genuine Spare Parts**" are made from the same high quality materials used for the original scooter. No parts would be sold to the market until they could meet the designed specifications through sophisticated engineering and stringent quality control. Therefore, it is necessary to purchase "**SYM Genuine Spare Parts**" from "**Authorized SYM Dealers or Franchised Dealers**" when replacing spare parts. If you buy cheap or fake substitute parts from the market, no guarantee can be provided either for the quality or durability. Also, it may result in unexpected troubles and lower the scooter's performance.

- Always use **SYM Genuine Spare Parts** to keep your scooters pure blood and to ensure its long service life.

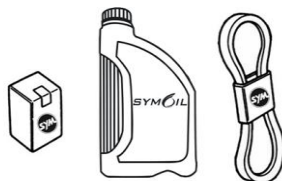



6. Parts Location

CRUISYM α 300 (LV30W2-EU)

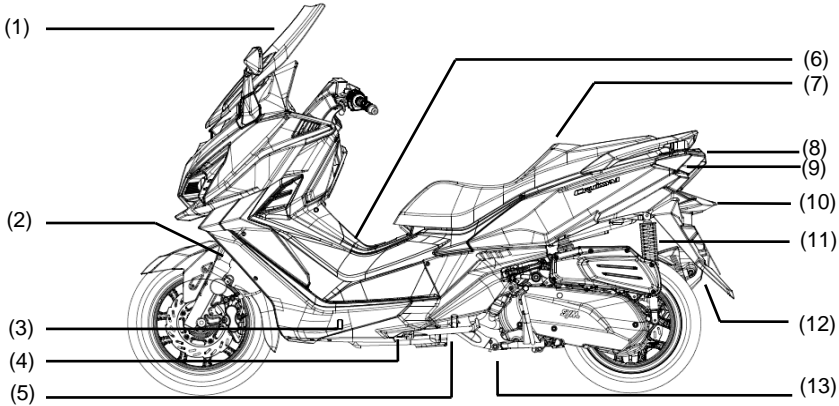

- | | | |
|--------------------------------------|---------------------------|----------------------------------|
| (1). Windscreen | (6). Fuel Lid | (11). Rear Shock Absorber |
| (2). Front Fork | (7). Seat / Luggage Box | (12). Muffler |
| (3). Coolant Level Inspection Window | (8). Tail / Brake Light | (13). Main Stand |
| (4). Side Stand Switch | (9). Rear Turn Indicator | (14). Rear View Mirrors |
| (5). Side Stand | (10). License Plate Light | (15). Right Turn Indicator/Front |

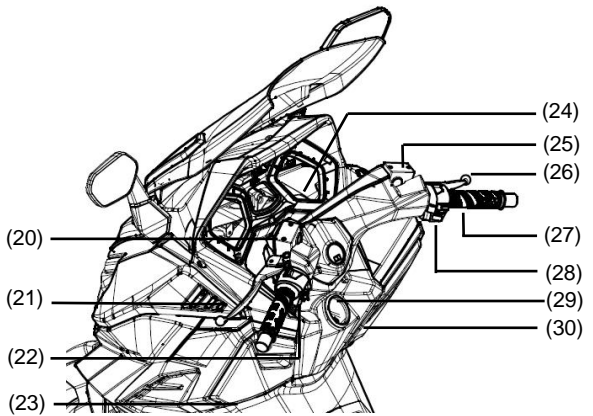
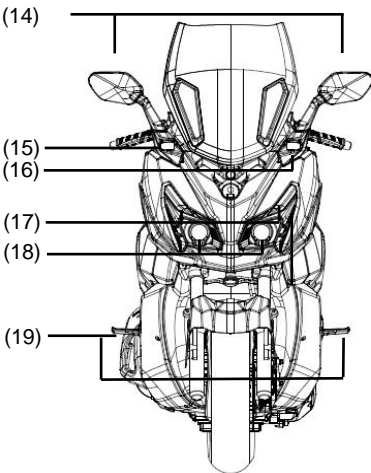

- | | | |
|----------------------------------|-----------------------------------|--------------------------------|
| (16). Left Turn Indicator/Front | (21). Rear Brake Lever | (26). Front Brake Lever |
| (17). Position Lights | (22). Left Handlebar Switches | (27). Throttle Grip |
| (18). Headlight | (23). Battery Compartment | (28). Right Handlebar Switches |
| (19). Passenger Footrests | (24). Combination Instrument | (29). Ignition Switch |
| (20). Rear Brake Fluid Reservoir | (25). Front Brake Fluid Reservoir | (30). Front Compartment |



CRUiSYM α 125 (LV12W2-EU)

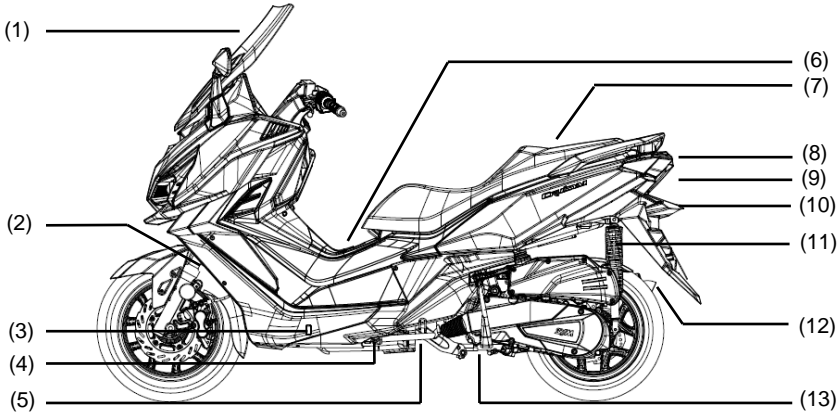

- | | | |
|--------------------------------------|---------------------------|----------------------------------|
| (1). Windscreen | (6). Fuel Lid | (11). Rear Shock Absorber |
| (2). Front Fork | (7). Seat / Luggage Box | (12). Muffler |
| (3). Coolant Level Inspection Window | (8). Tail / Brake Light | (13). Main Stand |
| (4). Side Stand Switch | (9). Rear Turn Indicator | (14). Rear View Mirrors |
| (5). Side Stand | (10). License Plate Light | (15). Right Turn Indicator/Front |

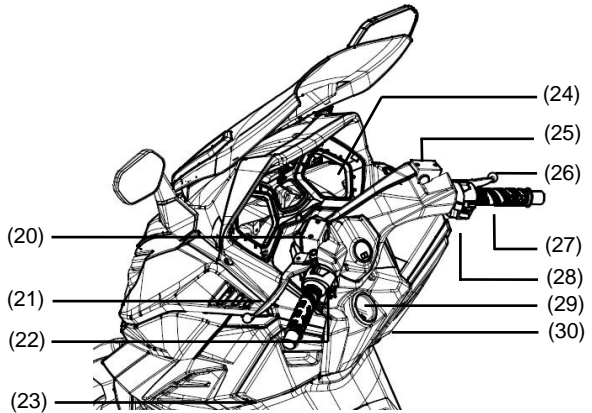
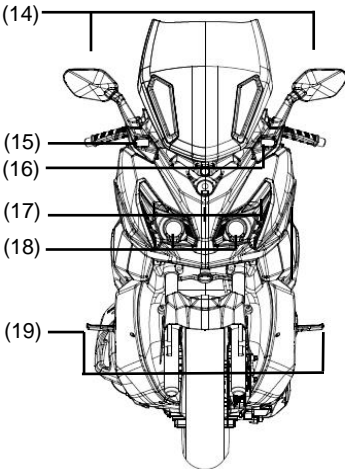

- | | | |
|----------------------------------|-----------------------------------|--------------------------------|
| (16). Left Turn Indicator/Front | (21). Rear Brake Lever | (26). Front Brake Lever |
| (17). Position Lights | (22). Left Handlebar Switches | (27). Throttle Grip |
| (18). Headlight | (23). Battery Compartment | (28). Right Handlebar Switches |
| (19). Passenger Footrests | (24). Combination Instrument | (29). Ignition Switch |
| (20). Rear Brake Fluid Reservoir | (25). Front Brake Fluid Reservoir | (30). Front Compartment |



Combination Instrument

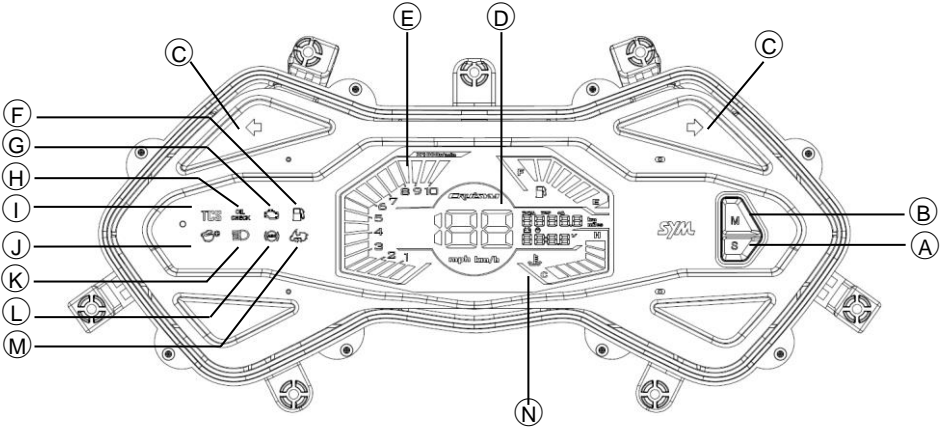

NOTE :

- Do not wipe plastic components, such as the instrument panel, the headlight, body covers, etc. with solvents, such as gasoline. Wiping plastic components with solvents can damage these components.



WARNING:

Never operate the instrument buttons while riding the scooter.

A S Button

Push this button to reset the trip meter, oil mileage meter in the multifunction meter.
Push this button to switch between battery voltage and clock of the multifunction meter (page 9).

B M Button

Press this button to switch meter mode of the multifunction meter (page 9).

C Turn Signal Indicator Light ⇄

The corresponding turn signal indicator light blinks when the turn signal switch is pushed to the right or left.

D Speedometer

The speedometer shows the current vehicle speed.

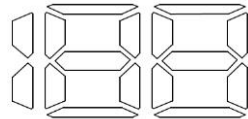

km/h



E Tachometer

This tachometer shows the engine speed in revolutions per minute (rpm). Do not operate the engine in the red zone .

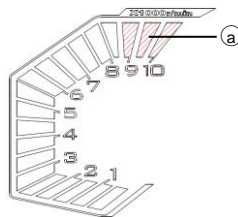

F Low Fuel Indicator

The low fuel indicator comes on when the fuel level goes down to 1 steady sector (page 9).

G EFi Warning Indicator

When turn the ignition switch to “ON” position, the EFi warning indicator remains on initially. It should go off immediately after the engine is running. It displays if the condition of the EFi system is working correctly. If there is any problem on the EFi system, the warning indicator remains on all the time. Please contact your authorized SYM dealer if this indicator goes on.

H Oil Check Indicator

The oil check indicator shows how long the engine oil is used. The oil check indicator comes on at every 1,000km riding distance according to the oil distance meter (page 9). When this indicator comes on, please check the oil level in the oil level inspection window or the dipstick (page 24). In oil meter mode, quickly press the S button twice to reset the oil check indicator.

I TCS Indicator (if equipped)

The TCS indicator flashes when traction control has engaged. If the traction control system is turned off, this indicator will go on. This indicator comes on whenever the ignition switch is turned off and turned to “On” position; this indicator will not go off until the engine is started. If the indicator does not go on after turning the ignition switch on, or if the indicator remains on when the engine is started, have the scooter checked by an authorized SYM dealer. Refer to page 8 for more information.

J Luggage Box Light Indicator

This indicator comes on when the luggage box light is lit up. This indicator goes off when the luggage box light is off.

K High Beam Indicator

This indicator comes on with high beam headlight is turned on.

L ABS Indicator (if equipped)

The ABS (Anti-lock Brake System) indicator comes on when the ignition switch is turned on and goes off shortly after the scooter starts moving. If the ABS is normal, it stays off. If there is something wrong with the ABS, the indicator comes on and stays on. When the indicator is on, the ABS does not function, but if the ABS fails, the conventional brake system will still work normally.

M Side Stand Down Indicator

This indicator comes on when the side stand (page 18) is kicked down. The engine cannot be started when the side stand is down. The engine will be stopped if the side stand is kicked down while the engine is running. This indicator goes off when the side stand is up.



(N) Multifunction Meter

- (a) Fuel gauge
- (b) Oil distance meter
- (c) Trip meter
- (d) Odometer
- (e) Multifunction display
 - Clock
 - Battery voltage gauge
- (f) Coolant temperature gauge

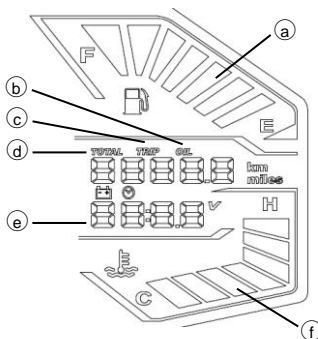

(a) Fuel Gauge

This digital fuel gauge shows the fuel level. There are 7 sectors in the fuel gauge.

If the fuel tank is full, all the 7 sectors come on.

The low fuel level indicator (page 8) comes on when there is only the first sector. Go refuel the fuel tank immediately.

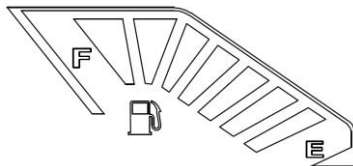

(b) Oil Distance Meter

This meter records how long the engine oil is used. The oil check indicator (page 8) comes on at every 1,000km riding distance according to this oil distance meter. When the oil check indicator comes on, please check the oil level in the oil level inspection window or the dipstick (page 24).

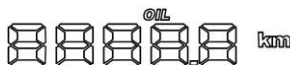

- In oil distance mode, quickly push S button twice to reset oil distance meter.
- Display range: 0~9999.9 km.

NOTE :

- If the oil distance meter is not reset, the oil check indicator will be on permanently until it is reset.
- If the oil distance meter is not reset, when the oil distance exceeds the maximum limit 9999.9 km, the meter will return to 0 km and continue adding up values. In this condition, the oil indicator will not go off until it is reset.
- This oil distance meter only shows in kilometers.

(c) Trip Meter

This trip meter shows the distance in kilometers since it was last reset to zero.



- In trip meter mode, push S button for more than 2 seconds to reset trip meter.
- Display range: 0~999.9 km.

NOTE :

- This trip meter only shows in kilometers.
- When the figures come to 99999, they will return to 0, and the trip meter starts working again.

d Odometer

This odometer shows the total distance in kilometers the scooter has been ridden. It cannot be reset.



NOTE :

- The data is maintained in the combination instrument even when the battery is disconnected.
- When the figures come to 99999, they will return to 0, and the odometer starts working again.
- This odometer only shows in kilometers.

e Multifunction Display

When the ignition switch is turned on, battery voltage will display for approximately 10 seconds. Then the below display mode can be shifted circularly by pushing the S button.

Clock → Battery voltage → Clock...

Push M button to switch the below display mode:

Odometer → Trip meter → Oil meter → Odometer...

Clock

This clock displays only 24-hour mode.

To set the clock, do the below steps:

- Turn the ignition switch on and wait for approximately 10 seconds until the clock displays.
- Push the M button for more than 2 seconds, the hour display starts blinking.

Push the S button to adjust the hours.



- Push the M button. The hour display stops blinking, and the minute display starts blinking. Push the S button to adjust the tens place in the minute display.



Push the M button. The tens place stops blinking, and the unit display starts blinking. Push the S button to adjust the units place in the minute display.



- Push M button to finish clock setting.

NOTE :

- When the battery is disconnected, the clock is reset to 12:00 and starts working again when the battery is reconnected.
- If the clock is idled about 30 seconds while setting, it will exit setting mode automatically and starts working again.
- If the ignition switch is turned off while setting the clock, the clock will exit setting mode when the ignition switch is turned on again.
- The clock works normally by the backup power even the ignition switch is turned off.

Battery Voltage Gauge

The battery voltage display shows current battery voltage. It is forced to display about 10 seconds when the ignition switch is turned on.

Display range: 9.0V~18.0V.



CAUTION:

- If the battery voltage is below 10.0V or above 16.0V when the ignition switch is turned on, and the engine is hard to start or cannot be started, have your scooter checked by an authorized SYM dealer.
- If the battery voltage is below 10.0V or above 16.0V when the engine is running, have your scooter checked by an authorized SYM dealer.

Coolant Temperature Gauge

This digital coolant temperature gauge displays the temperature of engine coolant.

The coolant temperature varies with changes in the weather and engine load.

If the seventh sector comes on when the scooter is in operation, stop the engine, move the scooter to a safe place, and check the coolant level in the reserve tank and the radiator fan (page 26).

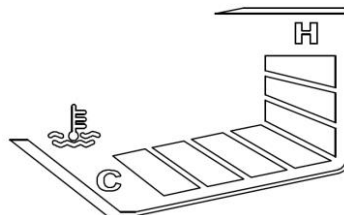

NOTE :

- This scooter is not equipped with a high coolant temperature indicator.
- The coolant temperature gauge will not blink when the coolant temperature is too high.
- Please take notice of the coolant temperature gauge when the engine is running.

Ignition Switch

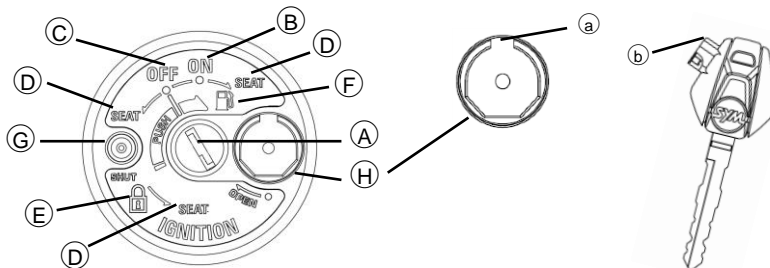

IGNITION SWITCH

IGNITION KEY

A Ignition Key Slot

Insert the ignition key into the ignition key hole to operate the ignition switch.

B “On” Position **ON**

Engine can be started in this position. Ignition key cannot be removed. Electrical equipment can be used. Headlight (position light) comes on in this position. The USB charge unit can be used in this position.

C “Off” Position **OFF**

Engine can be turned off in this position. Electrical circuits will be turned off.

D “Seat Open” Position **SEAT**

The seat can be opened in these positions.

- In “On” position, turn the ignition key clockwise, the ignition key will return to “On” position automatically.
- In “Off” position, turn the ignition key anti-clockwise, the ignition key will return to “Off” position automatically.
- In “Lock” position, turn the ignition key anti-clockwise, the ignition key will return to “Lock” position automatically.

E “Lock” Position

The handlebar can be locked in this position.

- Turn the ignition key to “Off” position to stop the engine.
- Turn the handlebar fully to the left.
- Push and turn the ignition key anti-clockwise to lock the handlebar.
- The ignition key can be removed in this position.
- To unlock the handlebar, turn the ignition key clockwise to “Off” position.

F “Fuel Lid” Position

The fuel lid can be opened in this position.

- Turn the ignition key to “Off” position.
- Push the ignition key and turn clockwise to open the fuel lid.

G Magnetic Shutter **SHUT**

This magnetic shutter button is designed to close the ignition key slot.

- In “Off” position, remove the ignition key and push this button to close the slot.
- In “Lock” position, remove the ignition key and push this button to close the slot.

H Shutter Opener

This shutter opener is designed to open the magnetic shutter.

- Align the projection **(b)** of the shutter key with the shutter slot **(a)**, and turn the shutter key clockwise to open.

NOTE :

- Do not attach too many objects to the ignition key to prevent interfering the workability of the ignition switch.

CAUTION:



- Never operate the ignition switch key when the scooter is running. Turning the ignition switch to “Off” position will shut off the electrical system and that may result in a dangerous accident. The ignition switch can only be turned off after the scooter is completely stopped.
- If the ignition switch remains in the “On” position for a prolonged period after the engine is stopped, the battery power will be reduced, and this may affect engine’s start capability.
- Lock the steering handle and remove the key before leaving the scooter. Do not leave the key in the ignition switch when leaving the scooter.

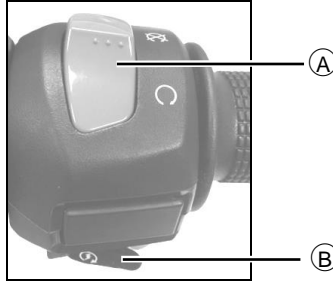

Right Handlebar Switches



A Engine Stop Switch

This switch should normally remain in the  position for the scooter to operate. In an emergency, switch to the  position to stop the engine.

NOTE :

- Even though the engine stop switch can stop the engine, it does not turn off all the electrical circuits.

B Starter Button

This starter button operates the electric starter when the engine is not running. Turn the ignition switch on; push this button while holding the front or rear brake lever to start the engine.

NOTE :

- This scooter is equipped with a permanently lit headlight; the headlight (low beam), position light, tail light, and the license plate light will light up once the ignition switch is turned on and engine started. The above mentioned lights cannot be turned off.
- Do not leave the scooter behind too much time after turning the ignition switch on.

Left Handlebar Switches

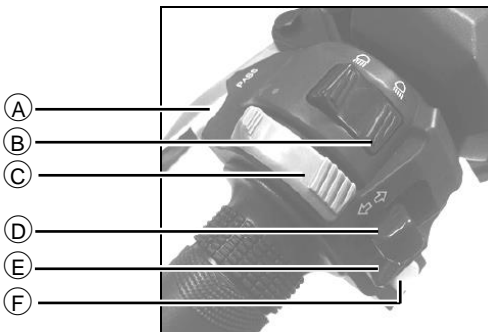



A Passing Light Button

When pushing the passing light button **PASS**, the high beam indicator light goes on to signal the driver of the vehicle ahead that you are about to pass. The passing light is shut off as soon as the button is released.



(B) Dimmer Switch



High and low beam can be selected with this switch. When the headlight is on high beam , the high beam indicator comes on (page 7).

-  High beam
-  Low beam

(C) Hazard Switch

Push the switch to  position with the ignition switch in “On” position. All the turn signal lights and turn signal indicators will blink.

(D) Turn Signal Switch

When the turn signal switch is turned to the left  or right , the corresponding turn signals blink on and off. To stop blinking, push the switch in.

(E) Horn Button

When the horn button is pushed when the ignition switch is turned on; the horn sounds.

(F) TCS Button (if equipped)

Push and hold the TCS button to turn on or off the traction control system when the ignition switch is turned on.

Windscreen

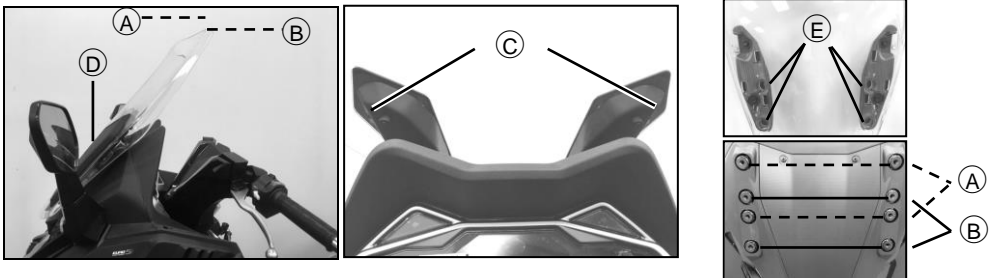

This scooter is equipped with a 2-position adjustable windscreen. Adjust the positions to fit your figure.

High position: **(A)**

Low position: **(B)**

- Remove the 2 screws **(C)** to remove the 2 windscreen garnishes **(D)**.
- Remove the 4 flange bolts **(E)**; select a position that you prefer and mount the windscreen.
- Install the 2 garnishes.



Fuel Tank Cap

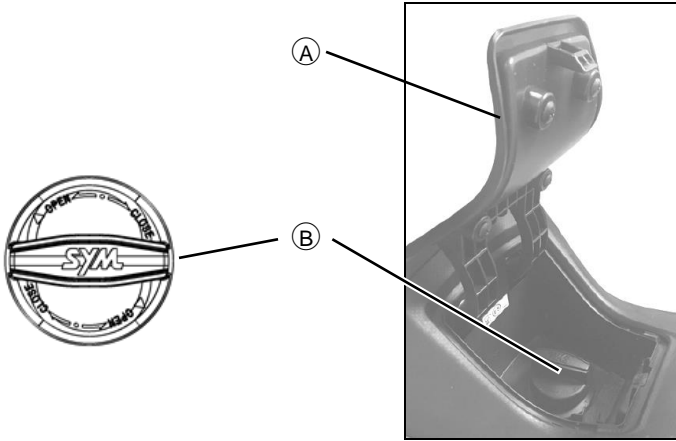

- Turn the ignition key to “Fuel Lid” position (page 12) to release the fuel lid ①.
- To open the fuel tank cap ②, turn it anti-clockwise.
- Put or hold the fuel tank cap securely.
- Fill in the fuel.
- Close the fuel tank cap and turn it clockwise until it is locked.
- Press the fuel lid to close it.

CAUTION:

- Gasoline is extremely flammable and can be explosive under certain conditions. Do not smoke and do not turn the ignition switch off when fueling. Make sure the area is well ventilated and free of any flammable source.
- Never fill the fuel tank to the top. If the tank is filled to the top, heat may cause the fuel to overflow.
- Make sure the fuel tank cap is closed securely after refueling.
- Wipe off the gasoline immediately if it is spilled out on the scooter.

Fuel Requirement

- Fuel type: Unleaded gasoline only.
- Octane number: Research Octane Number (RON) 92 or higher.
- Gasoline / alcohol blends: As known as gasohol, up to 5%.
- Fuel tank capacity: 12 L.



CAUTION:

- Use only unleaded gasoline to prevent engine damage. Leaded gasoline reduces the capability of the catalytic converter in the exhaust system.
- Use recommended octane number. Using lower octane gasoline will decrease engine performance.
- Never use fuels containing high concentration alcohol.
- Do not use contaminated gasoline.



Front Compartment

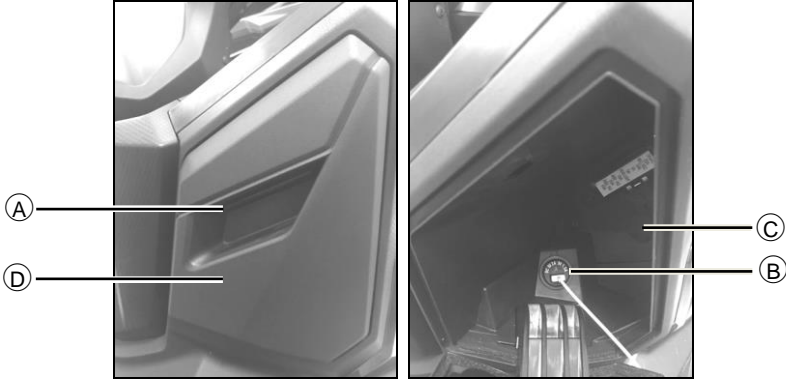

The front compartment is located on the right side of the ignition switch. The USB charge unit **(B)** and DC power outlet (12V, 10A, 120W) **(C)** are in the front compartment. Pull the latch **(A)** to open the compartment cover **(D)** to get access to the USB charge unit and DC power outlet. The USB charge unit and DC power outlets can charge low power consumption devices when the engine is running.

NOTE :

- Do not use the USB charge unit and DC power outlet when the engine is not running.
- To avoid blown fuse, do not charge devices exceed 10W with USB charge unit.
- Disconnect devices when leaving the scooter or after riding, and close the rubber caps securely to avoid water infiltration.

Luggage Box

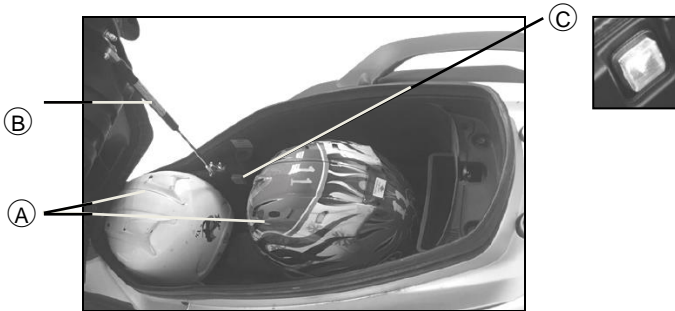

The luggage box is under the seat. Open the seat (page 12) to use the luggage box. Helmets **(A)** can be stored in the luggage box. Some helmets may not fit in the space due to the size or design. This scooter is equipped with a seat support **(B)** and a luggage box light **(C)**. The luggage box light comes on when the seat is opened.

- Maximum load: 10 kg.

NOTE :

- Do not exceed the maximum weight limit.
- The luggage box may be affected by engine heat. Do not put in valuables, food or objects which are flammable or susceptible to heat damage.



Side Stand



This scooter is equipped with a side stand (A). The side stand is used for parking the scooter. Do not sit on the scooter when it is on its side stand. Always kick the side stand fully up before riding.

This scooter is equipped with a side stand switch (B). When the side stand is on, the side stand down indicator comes on (page 9). The engine cannot be started when the side stand is on. The engine will be stopped when kicking down the side stand while the engine is running.

NOTE :

- Turn the handlebar fully to the left when using the side stand.

Main Stand

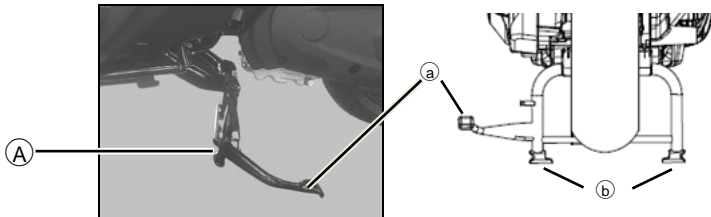

This scooter is equipped with a main stand (A). Use the main stand to park the scooter up right.

- Stand on the left side of the scooter and let down the main stand.
- Hold the left handle grip and the left side of the rear carrier.
- Press down the tip of the stand (a) with your right foot, make sure the 2 contact points (b) touching the surface firmly.
- Pull up and back.
- Turn the handle bar fully to the left.



Passenger Footrest

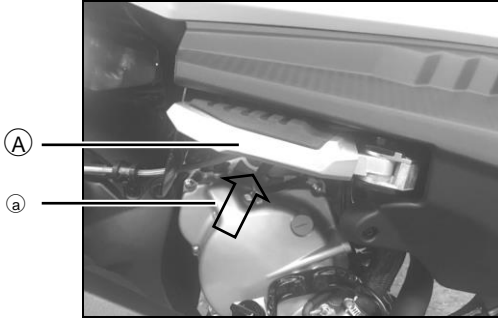

This scooter is equipped with 2 passenger footrests (A). Push (a) the footrests for passenger to use.

NOTE :

- Fold up the passenger footrests when there is no passenger sitting on the scooter.

7. How to Start the Engine

To Start the Engine

- Make sure the engine stop switch is in the \bigcirc position.
- Make sure the side stand is up.
- Turn the ignition key to "ON" position.
- Pull the front or rear brake lever and push the starter button with the completely closed throttle to start the engine.

CAUTION:

- Check the oil and the fuel volume before starting the engine.
- Release the starter button immediately after starting the engine.
- If the engine cannot be started after activating the starter 3 ~ 5 seconds, please slightly open the throttle grip then push the starter button to help starting the engine.
- Do not push the starter button for more than 10 seconds to prevent damaging the starter.
- If the engine cannot be started after several attempts, please turn the ignition switch off and wait 10 seconds for the next start.
- Do not push the starter button while the engine is running.
- The exhaust gas is toxic; please start the engine in areas with good ventilation.

To Stop the Engine

- Completely close the throttle.
- Turn off the ignition switch.
- Position the scooter on a firm, level surface with side stand / main stand down.



8. How to Ride the Scooter

Break-In

During the first 1,000 km of running, follow the below guidelines to ensure your scooter's reliability and performance.

- Avoid full throttle starts and rapid acceleration.
- Avoid hard braking.
- Ride conservatively.

Throttle Control

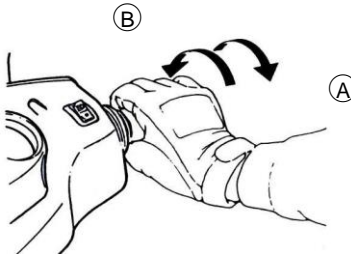

To accelerate, slowly open the throttle (A).

To decelerate, close the throttle (B).

Moving Off

- Make sure the side stand / main stand is up.
- Make sure the surrounding area is clear.
- Smoothly open the throttle to move off

⚠ CAUTION:

- Always open the throttle carefully particularly if you are unfamiliar with the scooter.
- New tires are slippery and may cause loss of control, it is necessary to establish normal tire grip in the break-in period.

Breaking

- Completely close the throttle, the engine will help slowing down the scooter.
- When stopping, always apply both brakes at the same time. Generally speaking, the front brake should be applied a bit more than the rear.
- Never lock the brakes or it will cause the tires to skid. When turning a corner, reduce your speed before getting into the corner.
- Even though this scooter is equipped with ABS or CBS, braking during turning a corner may cause wheel slip. It is better to limit and do not apply hard braking force when cornering.
- For emergency braking, focus on applying the brakes as hard as possible.





Anti-lock Brake System (ABS) (if equipped)

ABS is designed to help prevent the wheel from locking up when hard brakes are applied while running straight. The ABS automatically regulates brake force. Intermittently gaining gripping force and braking force helps prevent wheel lock-up and allows stable steering control while stopping. Brake control function is identical to that of a conventional scooter. The brake levers are used for the front brake and the rear brake.

Although the ABS provides stability while stopping by preventing wheel lock-up, remember the following characteristics:

- ABS cannot compensate for adverse road conditions, misjudgment or improper application of brakes. You must take the same care as with scooters not equipped with ABS.
- ABS is not designed to shorten the braking distance. On loose, uneven or downhill surfaces, the stopping distance of a scooter with ABS may be longer than that of an equivalent scooter without ABS. Pay more attention to such areas.
- ABS will help prevent wheel lock-up during straight-up braking, but it cannot control wheel slip which may be caused by braking during cornering. When turning a corner, it is better to limit braking to the light application of both brakes or not to brake at all. Reduce your speed before getting into the corner.

⚠ CAUTION:

ABS cannot protect the rider from all possible hazards and is not a substitute for safe riding practices. Be aware of how the ABS system operates and its limitations. It is the rider's responsibility to ride at appropriate speeds and manner for weather, road surface, and traffic conditions.

Traction Control System (TCS) (if equipped)

This traction control system lowers the engine power output in case of loss of traction in the rear wheel. This system helps maintain traction when accelerating on slippery surfaces, such as wet, muddy or unpaved roads. If sensors detect that the rear wheel is starting to slip, the traction control system intervenes by regulating engine power until traction is recovered.

TCS Indicator

When the ignition switch is turned on, the traction control system is automatically turned on. The traction control system can be turned off when the ignition switch is turned to "On" position; push and hold the TCS button (page 14) for approximately 3 seconds to turn off the traction control system. To turn on the traction control system, push and hold the TCS button for approximately 3 seconds then the TCS indicator will go off. The traction control system can only be turned off and turned back on when the scooter is stationary.

- TCS indicator goes off: with system turned on and scooter in motion, or when system is detecting wheel speeds.
- TCS indicator comes on: with system turned off by rider, or a malfunction occurs. If the system is turned off before starting the engine (with ignition switch in "On" position), this indicator will remain on after the engine is started.
- TCS indicator flashes: when system is intervening.

NOTE :

- The traction control system is automatically turned on whenever the ignition switch is in “On” position, even though the TCS indicator comes on in this condition, the traction control system is turned on.
- When traction control is intervening, you may notice changes in engine response or exhaust sound.
- This traction control system cannot detect sideward slide in the rear wheel while cornering.
- The traction control system does not prevent falls while cornering.
- If the scooter is trapped in mud, sand, or other soft surfaces; turn off the traction control system to free the scooter.
- If it is necessary to ride on low grip surfaces, such as gravel pavement, turn off the traction control system and carefully open throttle to allow the scooter to move on.
- Use only standard size tires. The traction control system will not work properly with non-standard size tires.

Traction control system reset

The traction control system may automatically deactivate (TCS indicator goes on) when the below situation occurs:

- When a wheel speed sensor fault is detected.
- ABS indicator comes on.
- When the EFi warning indicator comes on.

If the above mentioned happens, stop the scooter at a safe place and turn the ignition switch off, and turn it on, then start the engine to reset, the TCS indicator should go off. If the TCS indicator does not go off after resetting, have your scooter checked by an authorized SYM dealer as soon as possible.

NOTE :

- Do not turn off the traction control system and rev the engine when the scooter is on its main stand. The traction control system will be disabled and need to be reset.

 **CAUTION:**

- Traction control cannot protect the rider from all possible hazards and is not a substitute for safe riding practices. Be aware of how the traction control system operates and its limitations. It is the rider's responsibility to ride at appropriate speeds and manner for weather, road surface, and traffic conditions.
- Traction control cannot prevent loss of traction due to excessive speed when entering turns, accelerating abruptly at a sharp slope, or while braking, and cannot prevent front wheel slipping.

Park the Scooter

When approaching a parking position:

- Turn on turn indicator in advance, and smoothly close throttle to decrease speed.
- Fully close the throttle and pull brake levers smoothly.

After reaching the parking position:

- Reset the turn indicator switch, and turn the ignition switch off to stop the engine.
- To park the scooter, please refer to 18, “Side Stand” and “Main Stand”.
- Turn the ignition switch off and lock the handlebar.

 **CAUTION:**

- Do not turn the ignition key off while riding.
- The side stand is for uneven ground surface and for short time parking use. Turn the handlebar completely to the left to enhance stability.
- To avoid heat damage from the exhaust pipe, park the scooter away from pedestrians and children.



9. Maintenance and Adjustment

Importance of Maintenance

The maintenance and adjustments mentioned in this chapter must be carried out in accordance with “Routine Checks” and “Periodic Maintenance Schedule” to keep the scooter in well condition and to reduce air pollution. Maintenance is the owner’s responsibility. Be sure to inspect your scooter before every ride and perform the routine checks. The first maintenance is extremely important and must be performed.

⚠ WARNING:

- Always follow the inspection, maintenance recommendations, and schedules in this owner’s manual.

SYM cannot warn you of every conceivable hazard that can arise in performance. Only you can decide whether or not you should perform a given task. If you lack proper experience or doubt your ability, please contact your authorized SYM dealer for adjustments, maintenance, and repair work.

Routine Checks

Items	Key points
Engine Oil	Correct oil level.
Fuel	Sufficient fuel, no leaking.
Brakes	Front and rear brakes are effective.
Tires	Valve caps are fitted. No puncture.
Steering Handle	Any abnormal vibration or is difficult to turn?
Coolant	Coolant level is correct.
Electrical Equipment	Should work effectively.
Tension of Main Components	Should be tightened correctly.



Oil Level Inspection / Oil Change

Oil Level Inspection:

- If the engine is cold, please warm up the engine several minutes at idle speed.
- Stop the engine and wait for several minutes to allow the oil to settle.
- Set the scooter upright and check the engine oil level through the oil level inspection window **(A)**; or remove the dipstick **(B)** and wipe it clean, insert the dipstick till it seats but don't screw it in, the oil level should be between the upper **(a)** and lower marks **(b)**.
- Please top up the oil to the upper mark with the same oil when it is at the lower level.
- Please check the oil level every 1,000km.

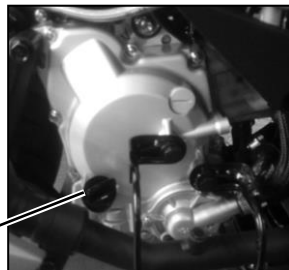
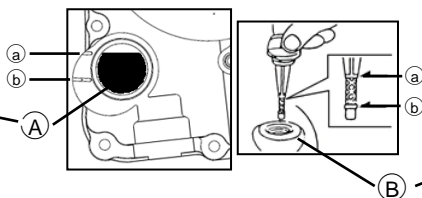

⚠ WARNING:

- Revving the engine before the oil reaches every part can cause engine seizure.

NOTE :

- Oil level will not be correct when checking the oil level with the scooter parked on an unlevelled ground or immediately after the engine stopped.

Oil Change:

- The oil change should be done by an authorized SYM dealer.
- The genuine “**SYMOIL**” are designed and recommended for your scooter.
- Please choose oil grade that is equal to (or greater than) SAE 10W-30 or 10W-40, API SL. SYM is not responsible for any damage caused by improper oil.
- The first oil change for the scooter is in the first 1,000km, change oil in every 5,000km afterwards.
- Check the crank case blow-by drain hose, drain it if needed.
- Total oil capacity: 1.4L (CRUiSYM α 300), 1.0L (CRUiSYM α 125).
- Periodic maintenance: 1.2L (CRUiSYM α 300), 0.8L (CRUiSYM α 125).

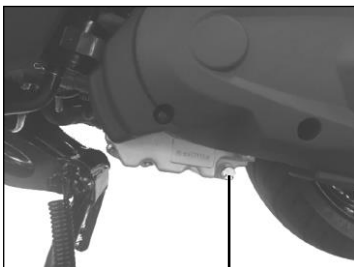

Oil Drain Bolt



Oil Filler Cap

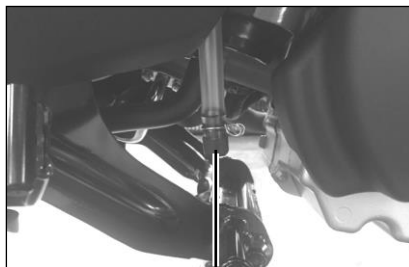

Crankcase Blow-by
Drain Hose

Although SAE 10W30 oil is recommended for most conditions, the oil viscosity may need to be changed to accommodate climate conditions in your riding area.

Recommended Oil

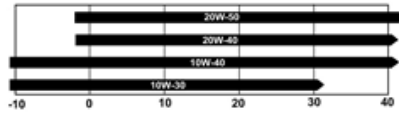

Cleaning of Oil Filter Screen:

The oil filter screen (A) should be cleaned by an authorized SYM dealer.

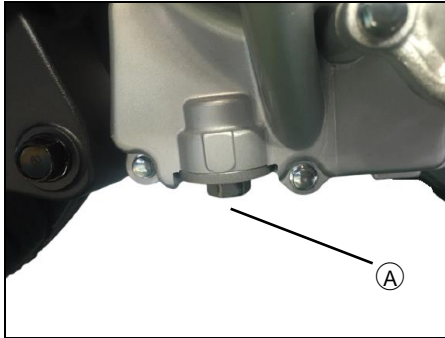

Transmission Oil Change

The transmission oil should be changed by an authorized SYM dealer.

- Grade: SAE 10W30 or 85W90. SYM is not responsible for any damage caused by improper oil.
- Total capacity: 180 cc (CRUiSYM α 300), 110 cc (CRUiSYM α 125).
- Periodic maintenance: 160 cc (CRUiSYM α 300), 100 cc (CRUiSYM α 125)

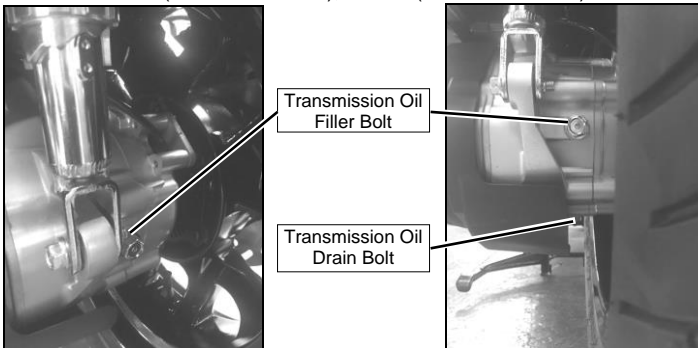

Fuel Inspection

Make sure the fuel is enough for the trip.

- Turn the ignition switch on, and check the fuel gauge. When the low fuel indicator comes on (page 7), it shows the fuel remains approximately 2.5 liter (reserve fuel), please fill up the tank immediately.
- Do not add too much fuel to the fuel tank.
- Make sure the fuel tank cap is securely closed.
- Recommended fuel: Unleaded 92 (RON) gasoline or greater.

Coolant Level Inspection / Filling

- Position the scooter on level ground and in an upright position. The coolant inspection window (A) can be seen on the left side of the floor panel.
- The coolant level must be between the "FULL" (a) and "LOW" (b) marks.
- Top up the coolant when the level is at the "LOW" mark.
- Remove the left floor panel mat (B).
- Remove the maintenance cap (C) with a flathead screw driver (D).
- Open the reserve tank cap (E) to fill in coolant.
- Reverse the above 3 steps to restore.

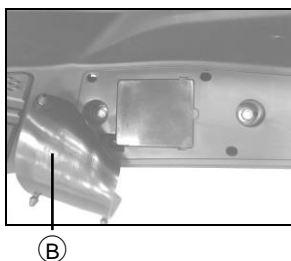
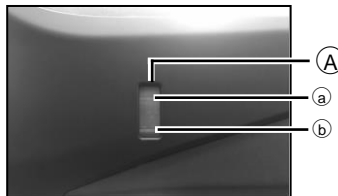

(B)

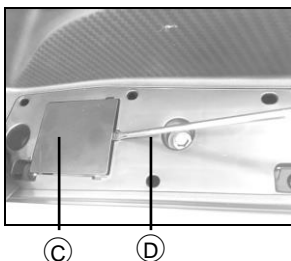

(C)

(D)

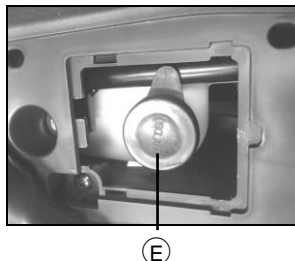

(E)

This scooter is filled with high quality coolant that is designed for the cooling system in the factory. It contains a 50% solution of ethylene glycol based antifreeze.

Coolant Change

Contact an authorized SYM dealer to have the coolant changed.

It is highly recommended to use "**SYM Long Life Coolant**" or equivalent products when filling or changing coolant. "**SYM Long Life Coolant**" is premixed and contains a 50% solution of ethylene glycol based antifreeze, and does not need to be diluted before topping up or changing. "**SYM Long Life Coolant**" also contains corrosion inhibitor to protect the cooling system.

- Radiator coolant capacity: 1.4 liters.

Please refer to the below list of antifreeze concentration.

Antifreeze concentration	Temperature	Remark
20%	-8	To ensure antifreeze performance, the original equipped coolant has 50% of antifreeze.
30%	-15	
40%	-24	
50%	-36	

Brake System Inspection

This scooter is equipped with a dual disk brake system on the front wheel and the rear wheel. If there is something wrong when applying the brakes, have the brake system checked by an authorized SYM dealer.

Front / Rear Brake Fluid Level Inspection:

- Set the handlebar to the front.
- Check the brake fluid level in the front / rear brake fluid reservoir.
- With the front brake reservoir held horizontal, the brake fluid level in the inspection window must be above the “LOWER” line (a).
- If the brake fluid level is below the lower level, contact your authorized SYM dealer to adjust the fluid level.
- Recommended brake fluid: DOT3 or DOT 4.

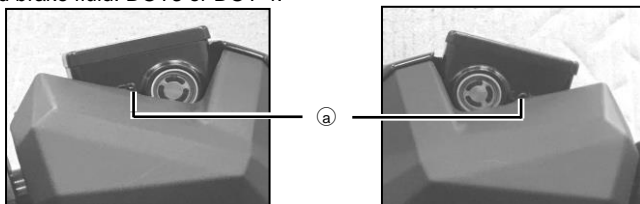

WARNING:

- Use only DOT3 or DOT 4 brake fluid.
- Brake fluid is easy to absorb moisture from the air; any absorbed moisture will reduce the braking efficiency greatly.
- Contact an authorized SYM dealer immediately if any brake fluid leakage is found.

Front / Rear Brake Pad Inspection:

- Inspect the brake pad wear of both front (A) and rear (B) disk brake calipers.
- If any pad lining thickness reaches the minimum thickness line (a), have the brake pads replaced by an authorized SYM dealer.

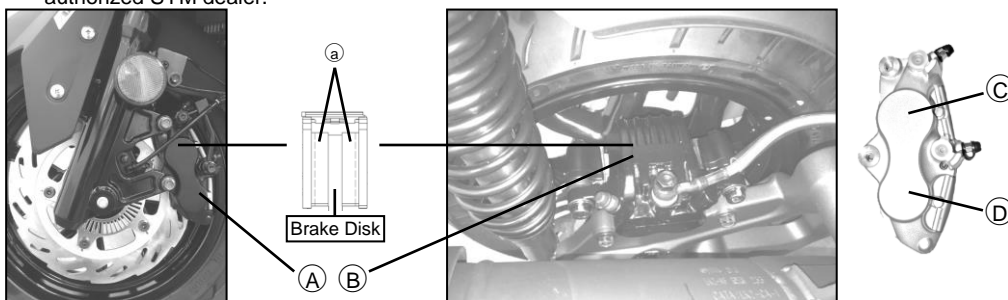

- This scooter is equipped with a dual- diameter opposed four piston front caliper (A), the wear of upper brake pads (C) may differ from the lower pads (D).

NOTE :

- Brake pads must be always replaced as a set.
- New brake pads require a break-in period.



Throttle Free Play Inspection

- Check that the throttle grip moves smoothly from full open to close.
- Check that there is 5°~ 10° (A) of throttle free play when turning the throttle grip back and forth.
- Have the throttle free play checked by an authorized SYM dealer.

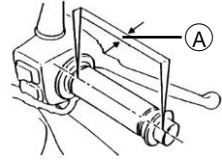

Tire / Tire Pressure Inspection

- Remove the air valve cap (A).
- Measure the tire pressure with a tire pressure gauge (B) often and inflate the tires to the recommended tire pressure.
- Visually inspect the tire for cracks and cuts (C), replace the tires when necessary.
- Measure the depth of the tread with a depth gauge (D), replace the tire that has worn down to the minimum allowable tread depth.
- Recommended tire pressure for standard tires: MAXXIS MA-PRO.
Front: 2.0 kgf/cm², 28 psi (120/70-14 55P)
Rear: 2.5 kgf/cm², 35 psi (140/60-13 63P)

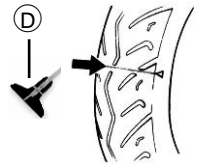
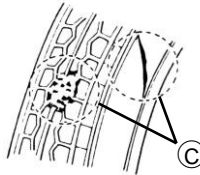
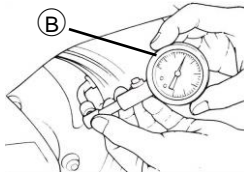
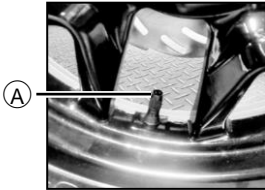

⚠ WARNING:

- Insufficient tire tread depth can make the scooter difficult to control.
- Please refer to the local regulations about tire tread depth.
- New tires are slippery and may cause loss of control.

Steering / Front Fork Inspection

- Visual inspect that the front forks (A) are damaged or have oil leakage.
- Compress the front forks by pushing down the steering handle to check that the forks can be operated smoothly.
- Check that the steering axle locknut is tightened.
- If any irregularity is found on the handlebar / front fork, contact your authorized SYM dealer.

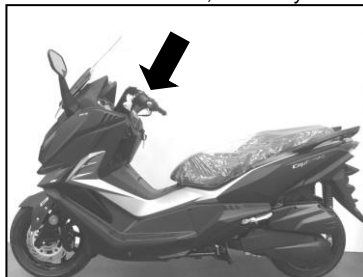
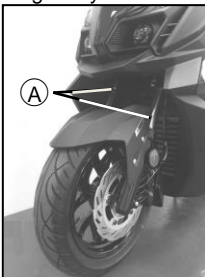



Fuse Inspection

Fuses are arranged in the fuse box ② located in the front compartment ① (page 17). Open the front compartment cover and then the fuse box to check the fuses.

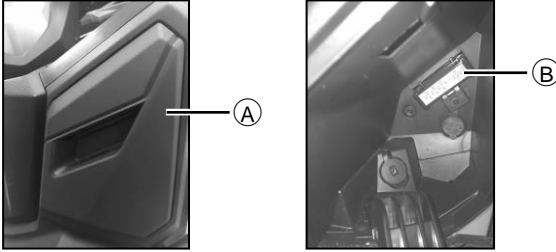

If a fuse fails, replace it with a new fuse of proper amperage. Do not replace it with any material other than the specified fuse. Have the scooter checked by an authorized SYM dealer if the fuse fails repeatedly.

Battery Inspection

This scooter is equipped with a sealed type battery. There is no need to check the electrolyte level or add distilled water. The battery is located in the battery compartment ②.

To take out the battery, do as the following instructions.

- Turn the ignition switch off.
- Remove the screw ① to remove the battery compartment cover ②.
- First disconnect the (-) terminal cable then the (+) terminal.
- Unscrew the battery band ③ and take out the battery.
- Clean the terminals ④ by using solution of baking soda and water.
- To install the battery, do in the reverse order of the above instructions.

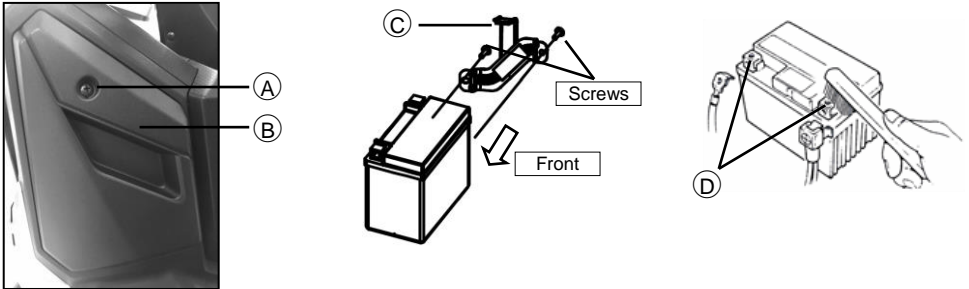



Spark Plug Inspection

Have the spark plug checked by an authorized SYM dealer. If the electrodes are contaminated with heavy deposits or the insulator is damaged, replace with a new one. Measure the spark plug gap with a wire type feeler gauge. The gap should be within 0.7 ~ 0.8 or 0.8 ~ 0.9 mm. If adjustment is needed, bend the side electrode (A) carefully.

- Recommended spark plug: NGK CR8E (CRUiSYM α 300), gap: 0.7 ~ 0.8 mm
NGK CPR8EA-9 (CRUiSYM α 125), gap: 0.8 ~ 0.9 mm

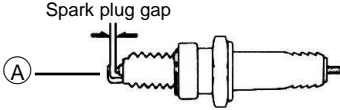

⚠ WARNING:

- Beware of the engine heat when inspecting the spark plug.

Air Cleaner / V-belt Air Cleaner Inspection

A dirty air cleaner element can reduce the engine performance and increase fuel consumption. Inspect the air cleaner by following the below instructions.

- Remove the screws (B) and remove the air box cover (A).
- Remove the screws (C) to take out the air cleaner element.
- If the air cleaner element (D) is damaged or too dirty, have it changed by an authorized SYM dealer.
- To install the element, do in the reverse order of the above instructions.

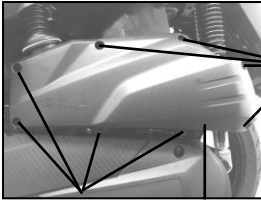

(B) (A)

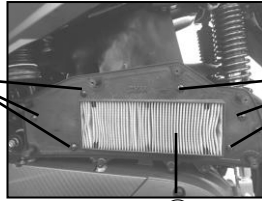

(C) (D) (C)

- Remove the air box drain hose (E), drain the hose if needed.
- Remove the bolts (F) and take out the left crankcase cover (G).
- If the V-belt air cleaner element (H) is damaged or too dirty, have it changed by an authorized SYM dealer.

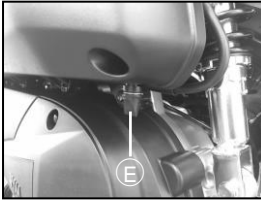

(E)



(H)

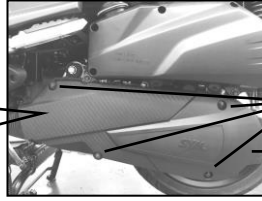

(F)

(G)

NOTE :

- CRUiSYM α 125 does not equip with v- belt air cleaner.
- Make sure to keep the dust from entering the inlet pipe during inspection.
- Use SYM genuine air filter element to ensure the engine performance.



Headlight Adjustment

Use a screwdriver to adjust the vertical adjuster (A).

Headlight aiming should be performed by an authorized SYM dealer.

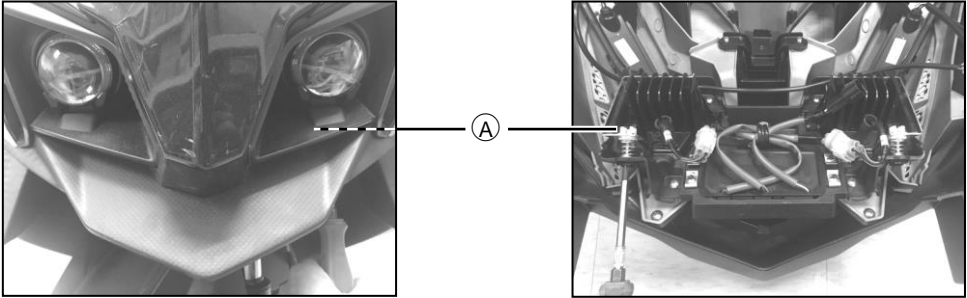

Rear Shock Absorber Adjustment

This scooter is equipped with 2 rear shock absorbers (A). Each shock absorber has 4 positions for spring preload adjustment. The standard position is 2.

- Turn the adjuster (B) anti-clockwise (a) to increase preload (harder).
- Turn the adjuster clockwise (b) to decrease preload (softer).

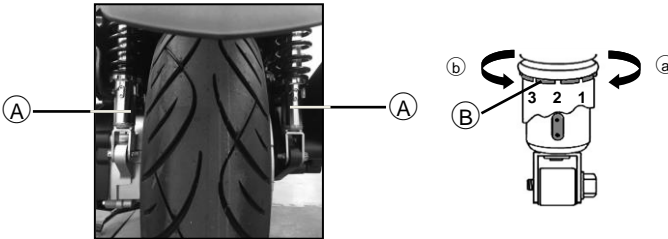

Contact your authorized SYM dealer for adjustment.

NOTE :

- Do not exceed the adjuster's limit.

General Lubrication

Lubricate the below parts with either engine oil or general grease in accordance with the "Periodic Maintenance Table" (page 34) or whenever the vehicle has been operated under wet or rainy conditions. Clean off rusty spots and wipe off any oil or grease.

- Side stand
- Front / rear brake lever
- Throttle cables

Vehicle Data Recorder

This scooter is equipped with an ECU that can record or collect vehicle data for trouble diagnosis and research. The data must be received by a special diagnostic tool when carrying out maintenance or check-up. SYM will not transfer the data to any third party except:

- The owner or user agrees.
- Stipulated by laws.
- In need of lawsuit.
- For research and development, and the data is irrelevant to an individual unit or the owner.



10. Taking Care of Your Scooter

Washing

Fully cool down the engine, muffler, brakes and other high-temperature parts before washing. We suggest you to cover the muffler's exhaust vent and shut the ignition switch slot.

- Rinse your scooter with cold water from a water hose to remove dirt.
- Mix a neutral detergent that is designed for scooters or automobiles and water in a bucket. Use a sponge to wash your scooter.
- After washing, rinse your scooter thoroughly with clean water to remove the residue.
- Use an air gun to blow off the water and use a clean soft cloth to dry your scooter.
- Carefully ride your scooter at a slow speed and apply the brakes several times to help drying the brakes.





NOTE :

- Do not rinse the radiator with high water pressure.
- Specially take care of the matt color plastic parts if they are equipped. Never wax matt color parts.

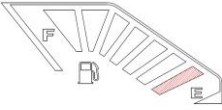

11. Trouble Shooting

Diagnosis When Engine Does Not Start

(1).Has the ignition switch key been turned to "ON" position?	(2).Is there enough fuel in the fuel tank or the fuel gauge needle is in the "E" position?	(3).Is the rear or front wheel brakes applied when pressing start button?
		
(4).Check that the engine stop switch is in the "O" position or not?	(5).Turn the ignition switch key "ON", and press horn button down, if the horn does not sound, the fuse may have been blown.	(6).Open the front compartment cover to check the fuse box, if the wire is obvious melted, replacement is needed.
		

Overheating

The engine is overheating when the below symptom occur:

- The seventh sector (H) of the coolant temperature gauge comes on.
- Sluggish acceleration.

Pull safely to the road side and perform the below procedure.

- Turn the ignition switch off to stop the engine then turn the ignition switch on.
- Check the operation of the radiator fan then turn off the ignition switch.

If the fan is not operating, do not start the engine and transport your scooter to an authorized SYM dealer. If the fan is operating, cool down the engine, inspect the cooling system hose and check if there is a leak. If there is a leak, do not start the engine and transport your scooter to an authorized SYM dealer.

EFi Warning Indicator On

If this indicator comes on while riding, the scooter may have a serious EFi system problem. Contact your authorized SYM dealer as soon as possible.

ABS Indicator On (if equipped)

If this indicator comes on in the below conditions, the scooter may have a serious brake system problem.

- The indicator comes on while riding.
- The indicator does not come on when the ignition switch is turned on.
- The indicator does not go off above 10 km/h.

Although the brake system will continue to work without anti-lock function, SYM suggest you to have your scooter checked by an authorized SYM dealer if any of the above symptoms occurs.



12. Periodic Maintenance

	Items	Maintenance Interval			
		Every 1,000km 1 Month	Every 5,000km 3 Months	Every 10,000km 6 Months	Every 15,000km 1 Year
1	Air cleaner element*	I	C	R	
2	Oil filter (mesh filter)	I	Clean every 10,000km		
3	Engine oil	(initial at 1,000km, second at 6,000km and then replace every 5,000km thereafter)			
4	Tire, pressure	I	I		
5	Battery	I	I		
6	Spark plug	I	I		R
7	Carbon Deposit cleaning on Throttle valve	I		I	
8	Steering bearing and handles	I	I		
9	Check Transmission for leakage	I	I		
10	Check crankcase for leakage	I	I		
11	Transmission Oil	(initial replace at 1,000km, and then replace every 10,000km thereafter)			
12	Brake Fluid	I	Replace every 30,000km		
13	Drive Belt/roller/Drive Pulley			C	R
14	Fuel tank tubes and Fuel filter	I	I		
15	Throttle valve operation and cable	I	I		
16	Bolts and nuts	I	I		
17	Cam Chain	I		I	
18	Valve clearance	I		I	
19	Shock absorbers	I		I	
20	Front/rear suspension	I		I	
21	Main/side stand	I/L		I/L	
22	Crankcase Blow-by system (PCV)	I	C		
23	Coolant	I	I		R
24	Cooling fan, tubes	I	I		
25	Clutch, Clutch outer, Driven pulley			C	
26	Brake mechanism/brake lining (pads) **	I	I		
27	Light, Switches and Electrical system	I	I		

Code: I ~ Inspection, cleaning, and adjustment R ~ Replacement

 C ~ Cleaning (replaced if necessary) L ~ Lubrication

* Replace the filter every 5000km under dusty environment. Never use compressed air to clean the filter. Replace if necessary.

** Clean and replace the internal component of brake caliper, master cylinder every 10,000km if necessary.

 Replace brake fluid every 2 years / 30,000km.

 Replace brake hose every 4 years / 60,000km.

☆ The above maintenance schedule has to be done if either mileage or duration had reached its designated maintenance criteria.

If any problem or question raised about your scooter, please contact your SYM authorized dealer regardless the service schedule.

☆ Have your scooter checked and maintained periodically by your SYM Authorized Dealer or Franchised Dealer to keep the scooter at the optimum condition.

☆ Check and maintain your scooter more frequently if necessary, such as frequently high speed / long distance driving, dusty environment, etc.



13. Specification

		CRUiSYM α 125 (LV12W2-EU)	CRUiSYM α 300 (LV30W2-EU)
Frame	Overall length	2,175 mm	
	Overall width	760 mm	
	Overall height	1,440 mm	
	Wheel base	1,530 mm	1,550 mm
	Ground clearance	130 mm	
	Caster	28°	
	Trail	140 mm	
	Min. turning radius	2.6 m	
	Maximum load	359 kg	374 kg
	Curb weight	179 kg	194 kg
	Luggage box capacity	48L	
	Seat height	750 mm	760 mm
	Fuel tank capacity	12 L	
Engine	Type	4T, SOHC, 4V, 1 cylinder, liquid cooled	
	Compression ratio	11.3:1	10.5:1
	Displacement	124.9 cm ³	278.3 cm ³
	Bore × stroke	53 mm × 56.6 mm	75 mm × 63 mm
	Max. horse power	13.3PS @ 8750 rpm	26.0PS @ 7500 rpm
	Max. torque	1.15kg-m @ 6750 rpm	2.67kg-m @ 6750 rpm
	Idle speed	1,800 rpm	1,550 rpm
	Starting system	Electric starter	
	Fuel system	EFI (fuel injection)	
	Fuel	Unleaded 92 (RON) gasoline or greater	
	Ignition system	Battery and coil	
	Spark plug	NGK CPR8EA-9	NGK CR8E
	Coolant capacity	1.4 L	
Transmission	Clutch / transmission	Centrifugal, CVT	
	Final reduction ratio	9.7	7.03
Lubrication System	Engine oil	SAE 10W30 or 10W40, API SL or greater	
	Gear oil	SAE 10W30 or 85W90	
	Lubrication system	Forced, wet sump	
	Engine oil capacity (total)	1.0 L	1.4 L
	Engine oil capacity (change)	0.8 L	1.2 L
	Gear oil capacity (total)	110 cc	180 cc
Gear oil capacity (change)	100 cc	160 cc	

		CRUiSYM α 125 (LV12W2-EU)	CRUiSYM α 300 (LV30W2-EU)
Brake System	Front / rear tire	120/70-14 55P, 140/60-13 63P	
	Front / rear tire pressure	2.0 kgf/cm ² (28 psi), 2.5 kgf/cm ² (35 psi)	
	Front / rear rim	14 × MT3.0, 13 × MT4.0	
	Rim material	Aluminum alloy	
	Front brake disk	260 mm	
	Rear brake disk	240 mm	
	Front brake caliper	4-piston	4-piston
	Rear brake caliper	2-piston	2-piston
	Brake fluid	DOT 3 or DOT 4	
Suspension System	Front	Telescopic fork	
	Rear	Dual shock absorber	
Electrical Equipment	Head light	LED 12V 12.5W *2/ 12V 22.1W *2	
	Rear / brake light	LED	
	Turn indicator	LED *4	
	Battery	MF, YTX9-BS/GTX9-BS, 12V 8Ah	MF, GT12A-BS, 12V 10Ah

* Specifications or equipment are subject to change without notice.

14. Serial Number/Labels location

The labels on your scooter provide important safety information. Read the labels thoroughly and do not remove them. Contact your authorized SYM dealer for replacement if any label is missing or damaged.

Tire Pressure Caution Label

CAUTION	IMPORTANT
TIRE PRESSURE: FRONT:28PSI (2.0kgf/cm ²) REAR:35PSI (2.5kgf/cm ²)	PRESSION DES PNEUMATIQUES: AVANT:28PSI (2.0kgf/cm ²) ARRIERE:35PSI (2.5kgf/cm ²)
TIRE SIZE: FRONT:120/70-14 55P REAR:140/60-13 63P	DIMENSIONS DES PNEUMATIQUES: AVANT:120/70-14 55P ARRIERE:140/60-13 63P

Manufacturer Label



SANYANG Italia S.r.l.
Via Pavia 25,
20814 - Varedo(MB),Italy.
Made in Taiwan

Luggage Box Caution Label

WARNING	ATTENTION
<input type="checkbox"/> MAX. LOAD IN TRUNK: 10kg <input type="checkbox"/> HEAT OF ENGINE WILL AFFECT THE TEMPERATURE INSIDE THE TRUNK. <input type="checkbox"/> FOR SAFE OPERATION, SEAT MUST LOCK. <input type="checkbox"/> VALUABLE AND BREAKABLE, DO NOT PUT IN. <input type="checkbox"/> WATER MAY LEAK INTO TRUNK WHILE WASHING MOTORCYCLE.	<input type="checkbox"/> CHARGE MAX. DANS LE COFFRE A BAGAGES: 10kg <input type="checkbox"/> LA TEMPERATURE A L'INTERIEUR DU COFFRE A BAGAGES EST FONCTION DE LA TEMPERATURE DU MOTEUR. <input type="checkbox"/> LA SELLE DOIT ETRE VERROUILLEE POUR UNE FONCTION EN TOUTE SECURITE. <input type="checkbox"/> NE PAS METTRE D'OBJETS FRAGILES OU DE VALEUR DANS LE COFFRE A BAGAGES. <input type="checkbox"/> LORS DU LAVAGE DU VEHICULE, DE L'EAU PEUT PENETREER DANS LE COFFRE A BAGAGES.

Riding Cautions Label

REMEMBER	RAPPEL
<ul style="list-style-type: none"> ■ PRESERVE NATURE. ■ ALWAYS WEAR A HELMET. ■ RIDE SAFELY. ■ READ OWNER'S MANUAL CAREFULLY BEFORE RIDING. 	<ul style="list-style-type: none"> ■ PRESERVER LA NATURE. ■ TOUJOURS PORTER UN CASQUE. ■ CONDUIRE AVEC PRUDENCE. ■ LIRE ATTENTIVEMENT LE MANUEL D'UTILISATEUR AVANT DE CONDUIRE.

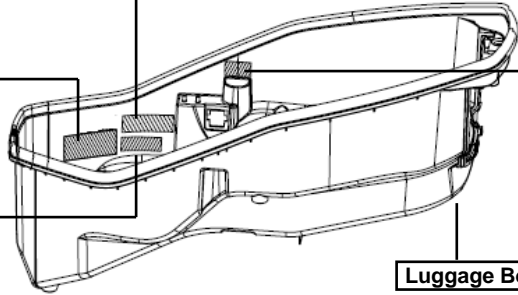

Luggage Box

E5 Alternative Fuel Label



Fuel Tank Cap

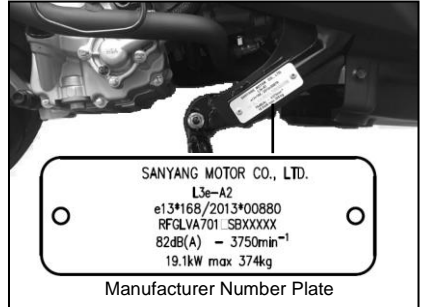

SANYANG MOTOR CO., LTD.
L3e-A2
e13*168/2013*00880
RFGVA701-SBXXXX
82dB(A) - 3750min⁻¹
19.1kW max 374kg

Manufacturer Number Plate

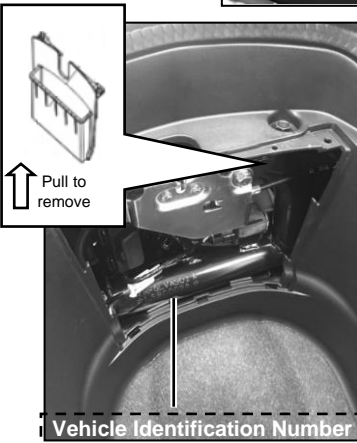

Vehicle Identification Number

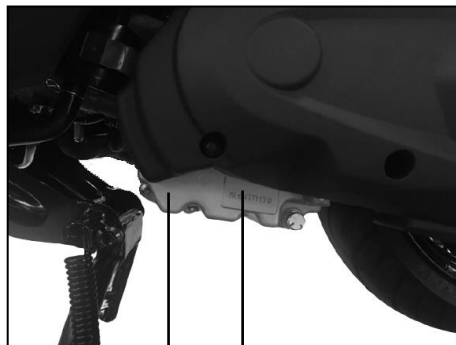

Left Crankcase

Engine Number